

FROM ADAPTED AND COMPUTERIZED THERMO-MECHANICAL EQUIPMENTS TO MODELLING AND THE TIME-EVOLUTION BEHAVIOUR IN Cu-Zn-Al SHAPE MEMORY ALLOYS

A. Isalgue, A. Torralba and V. Torra

Dep. Fisica Aplicada-ETSECCPB Universitat Politecnica de Catalunya Jordi Girona Salgado
31 E-08034 Barcelona, Spain

Abstract

Using two similar high resolution computer controlled stress-strain-temperature set-up of equivalent resolution (1 mN, 0.1 μm , 5 mK) the detailed study of the martensitic transformation in single crystals of the Cu-Zn-Al shape memory alloys is realized. The devices can obtain 20 or 150 N in applied force, 2 or 4 mm in length and can be operated near room temperature (between 280 and 360 K). The analysis of the hysteresis domain in single crystals clearly visualises the intrinsic characteristics of the material (pseudoelasticity, nucleation, interface friction) and enables the obtention of parameters for physical models of the hysteretic behaviour in force – lengthening – temperature and, eventually, time-dependent processes. The observation of time evolution shows the ‘recoverable martensite creep’ associated to a microstabilization process.

Keywords: computerized equipment, friction, martensitic transformation, modelling, nucleation, shape memory alloys, testing machine

Introduction

Using the Shape Memory Alloys (SMA) as continuous actuators, with little hysteresis and for long periods of time requires accurate knowledge of their behaviour and, also, a satisfactory modelisation (see 1 and related references). Experimental analysis required having instrumentation permitting detailed study of the complexity inherent in the SMA. In fact, thermoelastic martensitic transformation is associated with the appearance and interaction of large number of martensite domains among themselves and with the parent-phase domains. This situation, permitting adaptability (and training) of the material to the desired shape, also causes the material response to be easily affected by the instrumentation used. Furthermore, both phases (in this work, β -phase and 18 R martensite) are outside of the thermodynamic equilibrium. This is the origin of the material time evolutions.

In order to eliminate the actions of the experimental equipment (results in Ref. [2] are dependent of the temperature resolution and reproducibility; see, for instance, [3, 4], there have carefully designed systems of thermomechanical

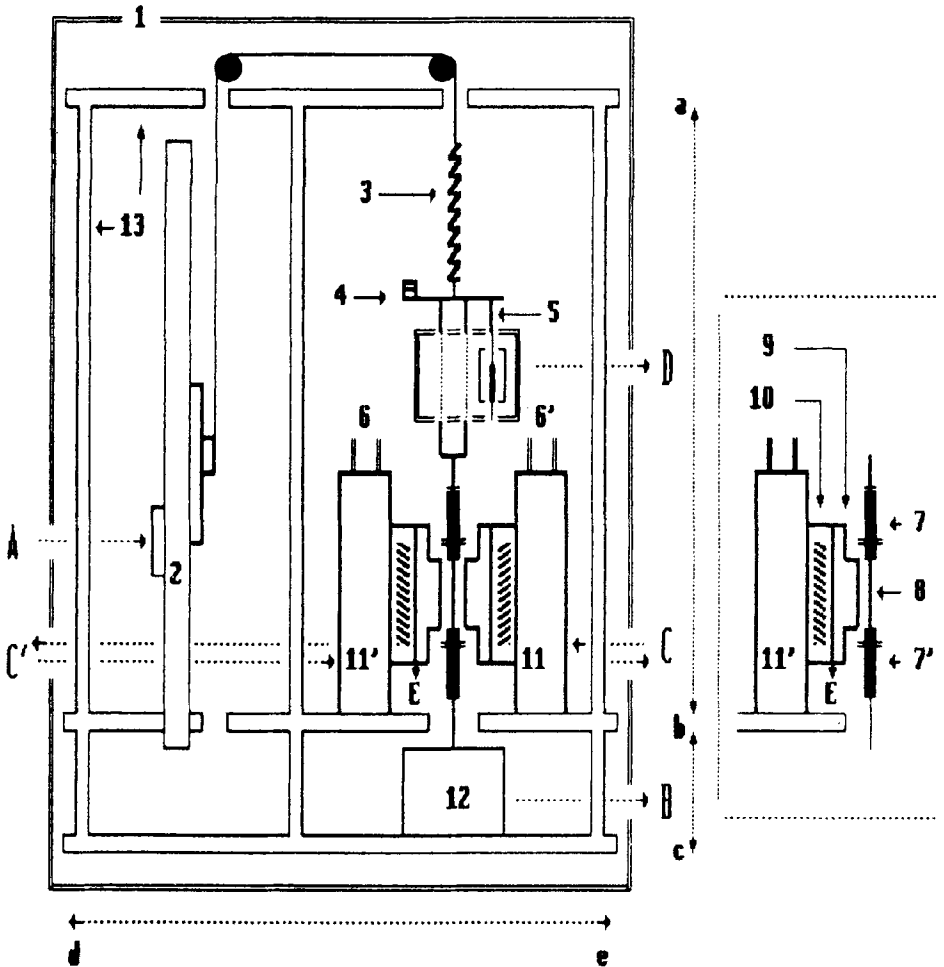

Fig. 1 Thermomechanical set-up (schematic); 1) thermostated thermal protection; 2) motorized displacement (Charly Robot); 3) spring; 4) compensatory mass; 5) lengthening measurement (CHMB); 6 and 6') link with the external thermostat; 7 and 7') grips; 8) sample; 9) controlled temperature plates; 10) Peltier plates; 11 and 11') reference temperature; 12) force measurement using HBM load cell; 13) internal structure (aluminium); Computer links: A) motor orders via RS-232; B) force measurement via amplifier and GPIB-bus; C and C') temperature measurement and control by Pt-100 and Peltier effect; D) lengthening measurement via HBM inductive sensor and GPIB-bus; E) measurement of the room temperature or the 'calorimetric' output via the GPIB-bus. Lengths (set-up with a full scale of the 200 N): ab 1.6 m, bc 0.35 m; de 0.45 m

analysis [5–7] (force (F), lengthening (x), temperature (T) and time (t)) derived from previous systems: thermomicroscopy and calorimetry [6, 8]. Having complementary resolutions, they permit the separation of several observable processes: processes of nucleation, interphase friction, evolution of local transformation temperatures; making it possible to construct a model with physical image in order to explain the hysteresis cycle of the material.

In this paper, from adapted thermomechanical equipment and using single crystals of Cu–Zn–Al, the effects on macroscopic nucleation of the plates and microplates are displayed. This, together with the effects of friction, thermoelasticity and external temperature action over critical stress, makes it possible to construct a representative model of the behaviour (F , x , T) of a set of martensite plates of the same variant. The experimental equipment permits separation of two kinds of effects of time on the material: evolutions after heat treatments and the microstabilization processes producing ‘recoverable martensite creep’.

Experimental set-up and experimental results

In order to make a detailed study of the transformation, the hysteresis cycle and, where appropriate, the partial loops, two high resolution F , x , T systems have been developed. Figure 1 shows a schematic picture for both systems. From a cable winding system or with a Charly-Robot stage a controlled stress over the material is obtained by means of a steel-wire fishing type connected to a spring. The maximum stresses are 20 N and 150 N respectively. The lengthening of the material is determined with the aid of an inductive sensor. Temperatures are controlled by means of Peltier plates and a suitable feed-back providing a resolution of 0.005 K [6–8]. When a Seebeck effect plate is placed in position, it is possible to obtain information on energy dissipation associated with transformation. Single crystals of Cu–Zn–Al alloys (electronic concentration 1.48) were used. Samples were carefully polished. The particular stress axis used produces one variant with the maximum strain ($\approx 9\%$).

Figure 2 shows a hysteresis cycle and internal loops for the nucleation process and the coalescence of the same variant. The single crystal (standard M_s near 280 K) underwent an air-quenching from 850°C and the observations were done one month after the heat treatment. Cycles with varying amplitude of the stress exercised were done. Various paths on diagram F x can be seen. We can obtain paths associated with interface friction and with involving partial or complete nucleation. For this, we must gradually reduce the final load in unloading. This tells that macroscopic nucleation is probably affected by three processes:

- 1) nucleation and growth of a microplate with a very small macroscopic lengthening;

- 2) subsequently appearance of the martensite plate and
- 3) for a small unload, the microplates remains and the growth in the next cycle is easier.

The slope in the internal loop (Figs 1–2) is associated with the intrinsic thermoelasticity. It is produced by creating stacking faults due to interaction between preexisting dislocations and the interface [9].

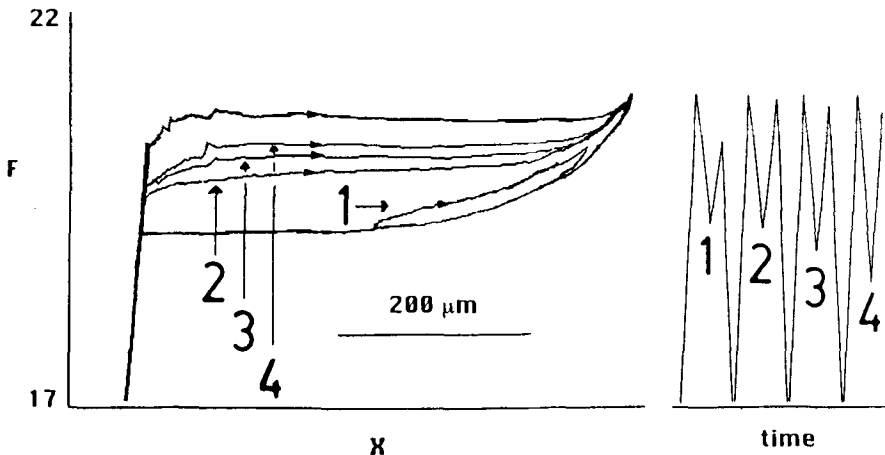

Fig. 2 Nucleation effects and frictional processes; left – force (N) vs. lengthening (μm) for a single variant (associated strain $\approx 9\%$); right – external force behaviour; left – 1) friction associated to the movement of the interfaces; 2, 3 and 4) different levels of the nucleation connected to the minimum of the unload value; right – associated cycles of the external force

Figure 3 shows a hysteresis cycle when the sample undergoes a water quenching (TT2) which produces a larger concentration of dislocations and, as a result, the intrinsic thermoelasticity [9, 10] hinders plate growth. When the external force is increased, nucleation of new plates is favoured. When the external stress is kept constant, growth of the amount of martensite can be represented in terms of time (Fig. 4) by means of an exponential contribution followed by a much slower growth. The process can be interpreted by considering that there are microstabilization processes activated by the presence and movement of the interfaces (increasing ≈ 0.25 K the transformation temperatures). More complicated pattern appears making internal and repetitive loops results can be explained by the martensite microstabilization and the β -recovery processes.

The experimental equipment permits determination of the effects of the cycling. In particular, when alloys with small γ precipitates are cycled mechanically or thermally, a considerable decrease in hysteresis is noted [11]. This

effect is linked to the formation of dislocation loops around each precipitate. Residual hysteresis much greater than in non-precipitate samples is related to the energy required to displace the martensite around the precipitate. This oc-

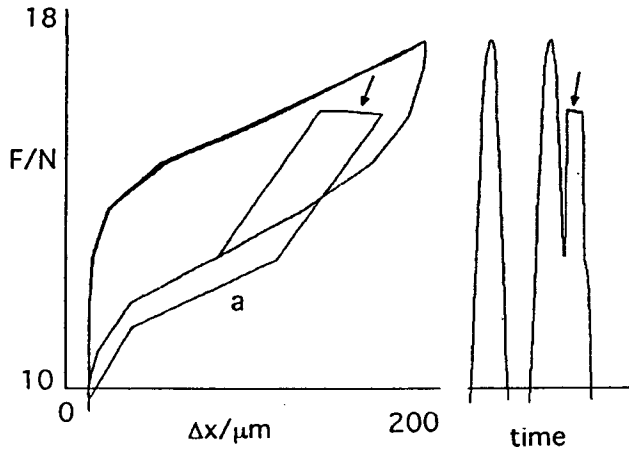

Fig. 3 Force (N) vs. lengthening (μm) and associated external force behaviour (right, schematic time scale); the arrow indicates a free growth of the martensite without external action; a) changed hysteresis by microstabilization

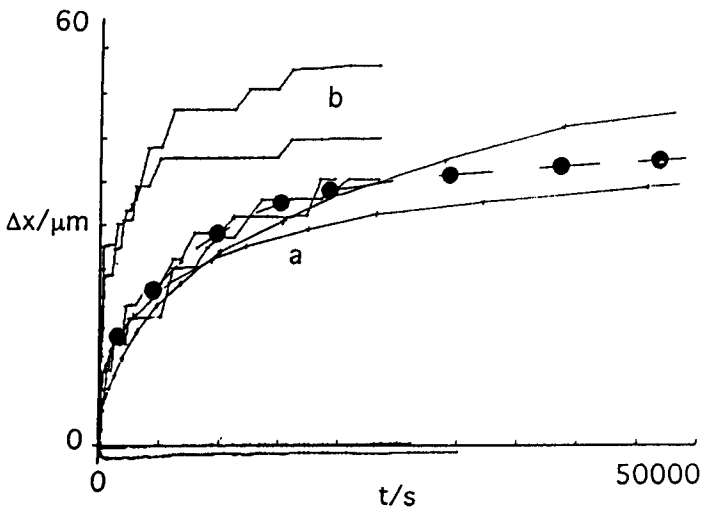

Fig. 4 Lengthening (μm) vs. time (s) at constant load for several stress-strain cycles. Positive curves associated to a previous load process, negative corresponds to the unloading part of the hysteresis cycle. a) martensite recoverable creep (MRC), previous load $< 1 \text{ kPa}\cdot\text{s}^{-1}$; b) MRC with previous load at $< 10 \text{ kPa}\cdot\text{s}^{-1}$; dots) exponential approach using a time constant (8000 s)

curs when the interface passes through the precipitate in the transformation and retransformation processes. These results are connected with improved training procedures.

Time-independent modelling

The macroscopic description includes many domains of martensite that progressively appear. Considering this it seems appropriate to think that the representative model will be formed by a group of equivalent domains that differ slightly in their transformation temperatures.

The calculation algorithm [5, 12, 13] uses a group of stepwise parameters to represent the characteristics and the actual state of the k -th plate $k \in [1, 2 \dots, N]$. Starting from the previous actions exerted by the force $F - \Delta F$ and the temperature $T - \Delta T$ that correspond to a length $x - \Delta x$, the new state corresponds to F and T and consequently to a length of x . The changes in each plate are analyzed and the stepwise parameters actualized. The relevant parameters of the model are:

- x_{\max}^o : maximum lengthening of a plate;
- f_{∞}^c : critical stress at the temperature T for the k -th plate;
- z_{if} : frictional force for the interface movement;
- z_{n_o} : frictional force for the parent to martensite nucleation;
- z_{n_1} : frictional force for the martensite to parent nucleation;
- $(df/dx)_o$: slope of the intrinsic pseudoelasticity;
- df/dT : slope of the Clausius-Clapeyron equation

The model has an independent numeric analysis for each plate starting from a well defined initial situation. In the initial part of the loading process (in parent phase) it can be verified that the external force does not surpass the frictional effects.

$$f_{\text{ext}} < f_{\infty}^c + z_{if} + z_{n_o} \quad (1)$$

when $f_{\text{ext}} > f_{\infty}^c + z_{if} + z_{n_o}$ the following 'thermoelastic equilibrium' equation is applied

$$f_{\text{ext}} = f_{\infty}^c + z_{if} + (df/dx)_o x \quad (2)$$

that allows to determine the lengthening as a function of f_{ext} . When f_{ext} decreases, the friction of the interfaces blocks the decreasing of the plate from the previous value x_c . In this part,

$$f_{\text{ext}} > f_{\infty}^c - z_{if} + (df/dx)_o x_c \quad (3)$$

if the value of f_{ext} decreases progressively the plate can progressively shrink in a new 'thermoelastic equilibrium'

$$f_{\text{ext}} = f_{\infty}^c - z_{\text{if}} + (df/dx)_0 x \quad (4)$$

and so on. If the transformation affects various domains — see, for instance the cycles associated to the samples TT2 — when they reach their maximum length they become coalescent. A process of 'parent-phase nucleation' is required for a retransformation process. The progressive appearance of new plates indicates that k -th plate uses a specific value of its reference critical stress $f_{\infty}^{c \text{ ref}}$.

The action of the changes in temperature is simulated through the equation of Clausius-Clapeyron. To do this we consider that the action of a temperature T is equivalent to the modification of the critical stress f_{∞}^c . Its value is determined through its reference value $f_{\infty}^{c \text{ ref}}$ associated to the reference temperature T^{ref} . The equations used are:

$$f_{\infty}^c = f_{\infty}^{c \text{ ref}} + (T - T^{\text{ref}})(df/dT) \quad (5)$$

Coherence between experimental and simulated curves with or without internal loops in F , x , T coordinates is satisfactory [12, 13]. The parameters required can be obtained using an algorithm developed from the Marquardt approach.

Conclusions

The development of automated high resolution equipment makes it possible to obtain detailed information of the behaviour of memory alloys: effects of friction of the interface and nucleation are different. In the case of the single crystals, it is easy to note the contributions of the martensite plates and microplates. Also, the evolutions caused by the coexistence of both phases probably linked to local order processes. Detailed study of the behaviour of one or more martensite plates makes it possible to construct a model, based on thermoelastic balance and frictional effects, which correctly describe single crystal F , x , T and, eventually, time behaviour.

* * *

Research carried out in the framework of the CICYT contracts MAT91-1276-E, MAT92-1025-C02-01, EEC contract CI1*-CT91-0943 and NATO grant number 920452. Enlightening discussions with Dr. F. C. Lovey and Dr. J. L. Pelegrina (CAB, Argentina) are gratefully acknowledged.

References

- 1 Proc. COMETT Course 1989 Science and Technology in Shape Memory Alloys ed. V. Torra (Palma de Mallorca: Universitat de les Illes Balears, Spain).
- 2 I. Grabec and E. Esmail, *Phys. Lett.*, A113 (1986) 376.
- 3 F. C. Lovey, J. Ortín and V. Torra, *Phys. Lett.*, A121 (1987) 353.
- 4 C. Picornell, C. Seguí, V. Torra, F. C. Lovey and R. Rapacioli, *Thermochim. Acta*, 113 (1987) 171.
- 5 V. Torra, *Thermochim. Acta*, 200 (1992) 413.
- 6 A. Amengual, A. Isalgue, F. Marco, H. Tachoire, V. Torra and V. R. Torra, *J. Thermal Anal.*, 38 (1992) 583.
- 7 A. Isalgue and V. Torra, *Meas. Sci. Technol.*, 4 (1993) 456.
- 8 A. Amengual and V. Torra, *J. Phys. E: Sci. Instrum.*, 22 (1989) 433.
- 9 F. C. Lovey, A. Amengual, V. Torra and M. Ahlers, *Phil. Mag.*, A61 (1990) 159.
- 10 F. C. Lovey, A. Amengual and V. Torra, *Phil. Mag.*, A64 (1991) 787.
- 11 A. Amengual, A. Isalgue, F. C. Lovey, F. Marco and V. Torra, *J. Thermal Anal.*, 38 (1992) 593.
- 12 F. C. Lovey, A. Isalgue and V. Torra, *Acta Metall. Mater.*, 40 (1992) 3389.
- 13 C. LExcellent, V. Torra and B. Raniecki, *J. Phys. III France*, 3 (1993) 1463.

Zusammenfassung — Mittels zweier einfacher hochauflösender, computergesteuerter Spannungs-Dehnungstemperatur-Apparate äquivalenter Auflösung (1 mN, 0.1 μm , 5 mK) wurde eine ausführliche Untersuchung der martensitischen Umwandlung in Einkristallen der Shape-Memory-Legierung Cu-Zn-Al durchgeführt. Die Apparaturen können eine eingesetzte Kraft von 20 oder 150 N, eine Länge von 2-4 mm erzielen. Sie können nahe Raumtemperatur (zwischen 280 und 360 K) gefahren werden. Die Auswertung des Hysteresenbereiches in Einkristallen zeigt deutlich die intrinsitischen Eigenschaften der Substanz (Pseudoelastizität, Keimbildung, Grenzflächenreibung) und ermöglicht den Erhalt von Parametern für das physikalische Modell des Hystereseverhaltens von kraft-, dehnungs-, temperatur- und eventuell zeitabhängigen Prozessen. Das Beobachten der zeitlichen Entwicklung zeigt das "behebbare Martensitkriechen" in Verbindung mit einem Mikro stabilisierungsvorganges.